



COMF ELECTRONIC COMPANY

EXPORTERS, IMPORTERS & MANUFACTURERS

香港 九龍灣臨興街 32 號美羅中心 1 期 15 樓 11 室

Flat 11, 15/F, METRO CENTRE 1, 32 LAM HING ST.,

KOWLOON BAY, HONG KONG

TEL: (852) 2770 5181

FAX (852)2798 8129





WEB: www.comf-hk.com

Email: sales@comf-hk.com

Product Data Sheet SBH-9VP



Specification

Cell Size:	1 X 9V Cell
Wire:	AWG 26, UL1007
Body:	ABS 94HB, Black With PCB Pins
Terminals:	Nickel plated steel Snap Terminals
Compliance:	   



SBH-9VAS Shown without leads

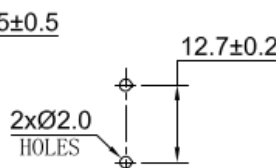
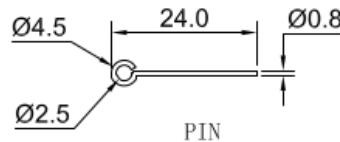
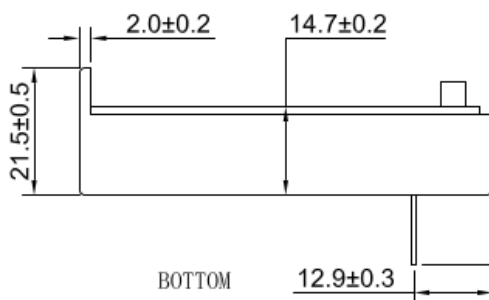
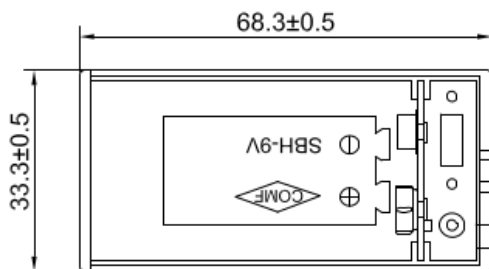

PCB/MOUNTING LAYOUT

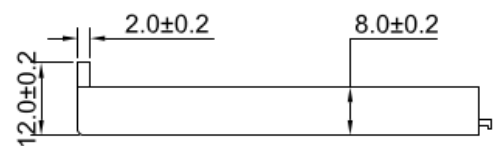
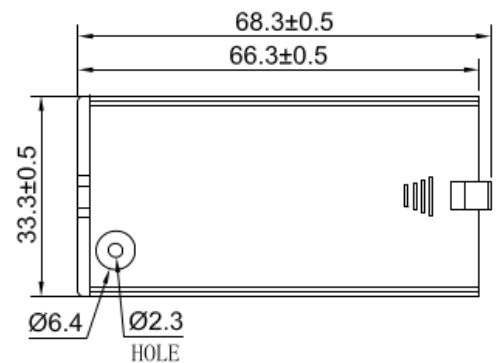

COVER